

EN Extra-heavy load springs
Yellow color

ES Muelles carga extra-fuerte
Color amarillo

FR Ressorts charge extra-forte
Couleur jaune

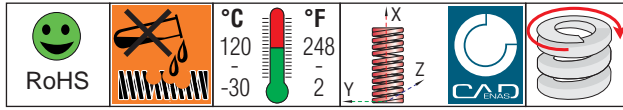
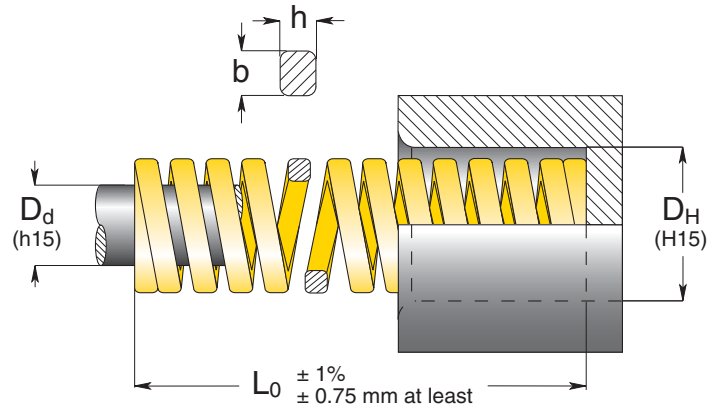

Code	D_H		L_0	R	A		B		C		D		E	Pcs
	Hole Diameter	Rod Diameter			Free Length	Spring Constant	17% L_0	20% L_0	22.5% L_0	25% L_0	do not use			
	b x h		$\pm 10\%$	$\pm 10\%$	+ 3.000.000	~ 1.500.000	300 - 500.000	100 - 200.000	approx.		do not use			
	mm	mm	mm	N/mm	mm	N	mm	N	mm	N	mm	N	mm	
G 10 - 025	10	5	25	36.8	4.3	158	5.0	184	5.6	207	6.3	232	7.7	50
G 10 - 032			32	27.9	5.4	151	6.4	179	7.2	201	8.0	223	10.6	50
G 10 - 038			38	23.7	6.5	154	7.6	180	8.6	203	9.5	225	12.6	50
G 10 - 044			44	19.2	7.5	144	8.8	169	9.9	190	11.0	211	13.8	50
G 10 - 051			51	16.5	8.7	144	10.2	168	11.5	189	12.8	211	16.2	25
G 10 - 064			64	13.2	10.9	144	12.8	169	14.4	190	16.0	211	20.4	25
G 10 - 076			76	10.9	12.9	141	15.2	166	17.1	186	19.0	207	25.2	25
G 10 - 305	1.9 x 1.6		305	2.6	51.9	135	61.0	159	68.6	178	76.3	198	111	10
G 13 - 025	12.5	6.3	25	58.5	4.3	252	5.0	293	5.6	329	6.3	369	8.1	50
G 13 - 032			32	43.9	5.4	237	6.4	281	7.2	316	8.0	351	9.9	50
G 13 - 038			38	36.0	6.5	234	7.6	274	8.6	308	9.5	342	12.9	50
G 13 - 044			44	30.3	7.5	227	8.8	267	9.9	300	11.0	333	14.1	25
G 13 - 051			51	26.2	8.7	228	10.2	267	11.5	301	12.8	335	17.4	25
G 13 - 064			64	21.2	10.9	231	12.8	271	14.4	305	16.0	339	21.0	25
G 13 - 076			76	17.1	12.9	221	15.2	260	17.1	292	19.0	325	26.4	25
G 13 - 089	89	14.5	15.1	219	17.8	258	20.0	290	22.3	323	31.5	20		
G 13 - 102	102	12.7	17.3	220	20.4	259	23.0	291	25.5	324	36.0	10		
G 13 - 305	2.6 x 2.0		305	4.3	51.9	223	61.0	262	68.6	295	76.3	328	111	10
G 16 - 025	16	8	25	118	4.3	507	5.0	590	5.6	664	6.3	743	8.5	50
G 16 - 032			32	89.0	5.4	481	6.4	570	7.2	641	8.0	712	11.0	50
G 16 - 038			38	72.1	6.5	469	7.6	548	8.6	616	9.5	685	13.2	25
G 16 - 044			44	60.9	7.5	457	8.8	536	9.9	603	11.0	670	14.7	25
G 16 - 051			51	52.3	8.7	455	10.2	533	11.5	600	12.8	669	17.7	25
G 16 - 064			64	41.2	10.9	449	12.8	527	14.4	593	16.0	659	21.9	25
G 16 - 076			76	34.1	12.9	440	15.2	518	17.1	583	19.0	648	27.8	20
G 16 - 089	89	29.5	15.1	445	17.8	525	20.0	591	22.3	658	31.2	20		
G 16 - 102	102	25.6	17.3	443	20.4	522	23.0	588	25.5	653	37.9	20		
G 16 - 115	115	22.4	19.6	439	23.0	515	25.9	580	28.8	645	44.5	10		
G 16 - 305	3.2 x 2.9		305	8.4	51.9	436	61.0	512	68.6	576	76.3	641	113	10
G 20 - 025	20	10	25	293	4.3	1260	5.0	1465	5.6	1648	6.3	1846	6.9	50
G 20 - 032			32	224	5.4	1210	6.4	1434	7.2	1613	8.0	1792	9.4	50
G 20 - 038			38	177	6.5	1151	7.6	1345	8.6	1513	9.5	1682	12.0	25
G 20 - 044			44	149	7.5	1118	8.8	1311	9.9	1475	11.0	1639	13.5	25
G 20 - 051			51	128	8.7	1114	10.2	1306	11.5	1469	12.8	1638	16.2	25
G 20 - 064			64	99.0	10.9	1079	12.8	1267	14.4	1426	16.0	1584	21.2	25
G 20 - 076			76	81.7	12.9	1054	15.2	1242	17.1	1397	19.0	1552	24.7	25
G 20 - 089	89	69.5	15.1	1049	17.8	1237	20.0	1392	22.3	1550	28.8	20		
G 20 - 102	102	60.6	17.3	1048	20.4	1236	23.0	1391	25.5	1545	34.8	20		
G 20 - 115	115	53.0	19.6	1039	23.0	1219	25.9	1371	28.8	1526	39.0	10		
G 20 - 127	127	47.5	21.6	1026	25.4	1207	28.6	1357	31.8	1511	43.0	10		
G 20 - 139	139	43.0	23.8	1023	28.0	1204	31.3	1345	35.0	1505	45.3	10		
G 20 - 152	152	39.0	25.8	1006	30.4	1186	34.2	1334	38.0	1482	50.4	10		
G 20 - 305	4.1 x 3.8		305	21.2	51.9	1100	61.0	1293	68.6	1455	76.3	1618	103	10



ISO 10243 Rectangular Wire

SERIES G

Code	D _H	D _d	L ₀	R	A	B	C	D	E	Pcs						
	Hole Diameter	Rod Diameter	Free Length	Spring Constant	17% L ₀	20% L ₀	22.5% L ₀	25% L ₀	approx.							
	b x h		± 10%	+ 3.000.000	~ 1.500.000	300 - 500.000	100 - 200.000	do not use								
	mm	mm	mm	N/mm	mm N	mm N	mm N	mm N	mm N							
G 25 - 025	25	12.5	25	459	4.3	1974	5.0	2295	5.6	2582	6.3	2892	7.3	50		
G 25 - 032			32	374	5.4	2020	6.4	2394	7.2	2693	8.0	2992	10.7	25		
G 25 - 038			38	300	6.5	1950	7.6	2280	8.6	2580	9.5	2850	12.0	25		
G 25 - 044			44	244	7.5	1830	8.8	2147	9.9	2416	11.0	2684	14.4	25		
G 25 - 051			51	208	8.7	1810	10.2	2122	11.5	2392	12.8	2662	17.4	25		
G 25 - 064			64	161	10.9	1755	12.8	2061	14.4	2318	16.0	2576	21.4	25		
G 25 - 076			76	131	12.9	1690	15.2	1991	17.1	2240	19.0	2489	26.9	20		
G 25 - 089			89	111	15.1	1676	17.8	1976	20.0	2220	22.3	2475	30.9	20		
G 25 - 102			102	96.3	17.3	1666	20.4	1965	23.0	2210	25.5	2456	36.7	20		
G 25 - 115			115	85.7	19.6	1680	23.0	1971	25.9	2217	28.8	2468	40.3	10		
G 25 - 127			127	76.3	21.6	1648	25.4	1938	28.6	2180	31.8	2426	45.1	10		
G 25 - 139			139	66.0	23.8	1571	28.0	1848	31.3	2066	35.0	2310	47.6	10		
G 25 - 152			152	63.5	25.8	1638	30.4	1930	34.2	2172	38.0	2413	53.5	10		
G 25 - 178			178	53.9	30.3	1633	35.6	1919	40.1	2159	44.5	2399	63.9	10		
G 25 - 203	203	47.0	34.5	1622	40.6	1908	45.7	2147	50.8	2388	70.2	10				
G 25 - 305	5.4 x 4.6	305	30.9	51.9	1604	61.0	1885	68.6	2121	76.3	2358	110	5			
G 32 - 038	32	16	38	480	6.5	3120	7.6	3648	8.6	4128	9.5	4560	11.4	20		
G 32 - 044			44	390	7.5	2925	8.8	3432	9.9	3861	11.0	4290	13.7	20		
G 32 - 051			51	320	8.7	2784	10.2	3264	11.5	3680	12.8	4096	15.6	20		
G 32 - 064			64	269	10.9	2934	12.8	3446	14.4	3876	16.0	4307	20.0	20		
G 32 - 076			76	219	12.9	2825	15.2	3329	17.1	3745	19.0	4161	24.4	20		
G 32 - 089			89	180	15.1	2723	17.8	3209	20.0	3611	22.3	4021	29.7	10		
G 32 - 102			102	155	17.3	2682	20.4	3162	23.0	3557	25.5	3953	35.1	10		
G 32 - 115			115	140	19.6	2744	23.0	3220	25.9	3623	28.8	4032	39.0	10		
G 32 - 127			127	124	21.6	2678	25.4	3150	28.6	3543	31.8	3943	42.8	10		
G 32 - 139			139	112	23.8	2673	28.0	3144	31.3	3512	35.0	3931	48.6	10		
G 32 - 152			152	102	25.8	2632	30.4	3101	34.2	3488	38.0	3876	52.4	10		
G 32 - 178			178	88.2	30.3	2672	35.6	3140	40.1	3532	44.5	3925	60.9	5		
G 32 - 203			203	76.0	34.5	2622	40.6	3086	45.7	3471	50.8	3861	69.2	5		
G 32 - 254			254	60.8	43.2	2627	50.8	3089	57.2	3475	63.5	3861	88.1	5		
G 32 - 305	7.3 x 5.9	305	49.0	51.9	2543	61.0	2989	68.6	3363	76.3	3739	104	5			
G 40 - 051	40	20	51	628	8.7	5464	10.2	6406	11.5	7206	12.8	8038	15.0	20		
G 40 - 064			64	487	10.9	5308	12.8	6234	14.4	7013	16.0	7792	19.5	10		
G 40 - 076			76	379	12.9	4889	15.2	5761	17.1	6481	19.0	7201	23.3	10		
G 40 - 089			89	321	15.1	4847	17.8	5714	20.0	6428	22.3	7158	26.7	10		
G 40 - 102			102	281	17.3	4861	20.4	5732	23.0	6449	25.5	7166	33.8	10		
G 40 - 115			115	245	19.6	4802	23.0	5635	25.9	6339	28.8	7056	36.2	10		
G 40 - 127			127	221	21.6	4774	25.4	5613	28.6	6315	31.8	7028	40.7	5		
G 40 - 139			139	195	23.8	4641	28.0	5460	31.3	6103	35.0	6825	44.5	5		
G 40 - 152			152	168	25.8	4334	30.4	5107	34.2	5746	38.0	6384	49.6	5		
G 40 - 178			178	150	30.3	4545	35.6	5340	40.1	6015	44.5	6675	59.9	5		
G 40 - 203			203	132	34.5	4554	40.6	5359	45.7	6029	50.8	6706	67.1	5		
G 40 - 254			254	107	43.2	4622	50.8	5436	57.2	6115	63.5	6795	86.3	2		
G 40 - 305			8.4 x 7.5	305	87.8	51.9	4557	61.0	5356	68.6	6025	76.3	6699	104	2	
G 50 - 064			50	25	64	709	10.9	7728	12.8	9075	14.4	10210	16.0	11344	19.3	5
G 50 - 076	76	572			12.9	7379	15.2	8694	17.1	9781	19.0	10868	24.2	5		
G 50 - 089	89	475			15.1	7173	17.8	8455	20.0	9512	22.3	10593	28.0	5		
G 50 - 102	102	405			17.3	7007	20.4	8262	23.0	9295	25.5	10328	33.5	5		
G 50 - 115	115	352			19.6	6899	23.0	8096	25.9	9108	28.8	10138	38.6	5		
G 50 - 127	127	316			21.6	6826	25.4	8026	28.6	9030	31.8	10049	41.4	5		
G 50 - 139	139	289			23.8	6878	28.0	8092	31.3	9046	35.0	10115	47.3	5		
G 50 - 152	152	239			25.8	6166	30.4	7266	34.2	8174	38.0	9082	50.2	2		
G 50 - 178	178	215			30.3	6515	35.6	7654	40.1	8611	44.5	9568	61.1	2		
G 50 - 203	203	187			34.5	6452	40.6	7592	45.7	8541	50.8	9500	67.7	2		
G 50 - 254	254	153			43.2	6610	50.8	7772	57.2	8744	63.5	9716	87.0	2		
G 50 - 305	11.5 x 9.0	305			127	51.9	6591	61.0	7747	68.6	8715	76.3	9690	104	2	
G 63 - 076	63	38			76	952	12.9	12280	15.2	14470	-	-	-	-	15.5	5
G 63 - 089					89	819	15.1	12360	17.8	14580	-	-	-	-	-	20.0
G 63 - 102			102	700	17.3	12110	20.4	14280	23.0	16065	25.5	17850	30.7	5		
G 63 - 115			115	620	19.6	12152	23.0	14260	25.9	16043	28.8	17860	34.9	5		
G 63 - 127			127	565	21.6	12204	25.4	14351	28.6	16145	31.8	17967	38.0	2		
G 63 - 152			152	458	25.8	11816	30.4	13923	34.2	15664	38.0	17404	47.2	2		
G 63 - 178			178	384	30.3	11635	35.6	13670	40.1	15379	44.5	17088	55.8	2		
G 63 - 203			203	337	34.5	11627	40.6	13682	45.7	15392	50.8	17120	64.8	2		
G 63 - 254			254	263	43.2	11362	50.8	13360	57.2	15030	63.5	16701	86.7	2		
G 63 - 305			11.6 x 14.9	305	218	51.9	11314	61.0	13298	68.6	14960	76.3	16633	106	2	

G
Metric

Estimated life 100.000 cycles

Load (N) = R (N/mm) x Deflection (mm)

1 N = 0.1 daN = 0.102 kgf

How to order: G 50 - 152

(Series) D_H - L₀

012 - 19 Special Springs