

| | | | |
|--|--|-------------------------------|--------------------|
| ISO 11901 - 3 B8 3180 220 000 004(MB) | VDI 3003 - Blatt 3 E24.54.815.G (PSA) | B2 4005 (BMW) 39D 997 (VW) | W-DX35-6204 (Ford) |
|--|--|-------------------------------|--------------------|

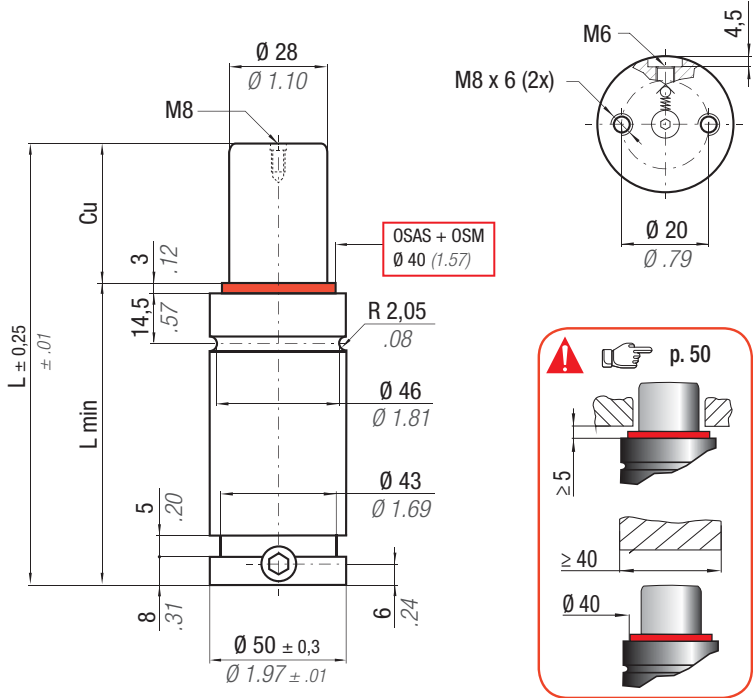

OSAS + OSM = OVER STROKE ACTIVE SAFETY + OVER STROKE MARKER



easyl MANIFOLD p. 211

ACTIVE SAFETY

* F_{1i} = Isothermal end force at 100% Cu p. 16
 ** F_{1p} = Polytrophic end force at 100% Cu



OSAS



USAS



OPAS

RV

| | | | | | | | | |
|--|--------------------------|---------------------------|-------------------------------------|-----------------------------------|---|---------------------------------------|-----------------------------|--|
| | °F 32 - 176 °C 0 - 80 | ΔP ± 0,33 %/°C | P max 150 bar 2175 psi | P min 20 bar 290 psi | S 6,15 cm ² 0.953 in ² | SPM ~ 20 - 100 (at 20°C) | Max Speed 1,8 m/s | Maintenance kit 39BMRV01000C |
|--|--------------------------|---------------------------|-------------------------------------|-----------------------------------|---|---------------------------------------|-----------------------------|--|

| CODE | Cu | | L | | L min | | F ₀ Initial force | | F _{1i} * End force | | F _{1p} ** End force | | V ₀ | | Maintenance kit | | PED 2014/68/EU |
|-------------------|-----|------|-----|-------|-------|------|---------------------------------|------|--------------------------------|------|---------------------------------|-------|-----------------|-----------------|-----------------|------|-------------------|
| | mm | inch | mm | inch | mm | inch | daN | lb | daN | lb | daN | lb | cm ³ | in ³ | ~Kg | ~lb | |
| RV 1000 - 010 - A | 10 | 0.39 | 58 | 2.28 | 48 | 1.89 | 920 ± 5% | 2068 | 1300 | 2923 | 1523 | 3424 | 25,0 | 1.53 | 0,49 | 1.08 | ✓ |
| RV 1000 - 013 - A | 13 | 0.51 | 64 | 2.52 | 51 | 2.01 | | | 1349 | 3033 | 1599 | 3595 | 29,0 | 1.77 | 0,51 | 1.12 | ✓ |
| RV 1000 - 016 - A | 16 | 0.63 | 70 | 2.76 | 54 | 2.13 | | | 1386 | 3117 | 1658 | 3727 | 34,0 | 2.07 | 0,54 | 1.19 | ✓ |
| RV 1000 - 019 - A | 19 | 0.75 | 76 | 2.99 | 57 | 2.24 | | | 1416 | 3183 | 1705 | 3833 | 39,0 | 2.38 | 0,56 | 1.23 | ✓ |
| RV 1000 - 025 - A | 25 | 0.98 | 88 | 3.46 | 63 | 2.48 | | | 1460 | 3282 | 1775 | 3990 | 48,0 | 2.93 | 0,61 | 1.34 | ✓ |
| RV 1000 - 032 - A | 32 | 1.26 | 102 | 4.02 | 70 | 2.76 | | | 1495 | 3361 | 1832 | 4118 | 59,0 | 3.60 | 0,67 | 1.48 | ✓ |
| RV 1000 - 038 - A | 38 | 1.50 | 114 | 4.49 | 76 | 2.99 | | | 1517 | 3410 | 1868 | 4199 | 69,0 | 4.21 | 0,72 | 1.59 | ✓ |
| RV 1000 - 050 - A | 50 | 1.97 | 138 | 5.43 | 88 | 3.46 | | | 1548 | 3479 | 1919 | 4314 | 88,0 | 5.37 | 0,81 | 1.79 | ✓ |
| RV 1000 - 063 - A | 63 | 2.48 | 164 | 6.46 | 101 | 3.98 | | | 1570 | 3528 | 1955 | 4395 | 108,0 | 6.59 | 0,92 | 2.03 | ✓ |
| RV 1000 - 075 - A | 75 | 2.95 | 188 | 7.40 | 113 | 4.45 | | | 1584 | 3560 | 1978 | 4447 | 127,0 | 7.75 | 1,01 | 2.23 | ✓ |
| RV 1000 - 080 - A | 80 | 3.15 | 198 | 7.80 | 118 | 4.65 | 1589 | 3571 | 1986 | 4465 | 135,0 | 8.24 | 1,05 | 2.31 | ✓ | | |
| RV 1000 - 100 - A | 100 | 3.94 | 238 | 9.37 | 138 | 5.43 | 1603 | 3604 | 2011 | 4521 | 166,0 | 10.13 | 1,21 | 2.67 | ✓ | | |
| RV 1000 - 125 - A | 125 | 4.92 | 288 | 11.34 | 163 | 6.42 | 1616 | 3632 | 2031 | 4566 | 205,0 | 12.51 | 1,41 | 3.11 | ✓ | | |

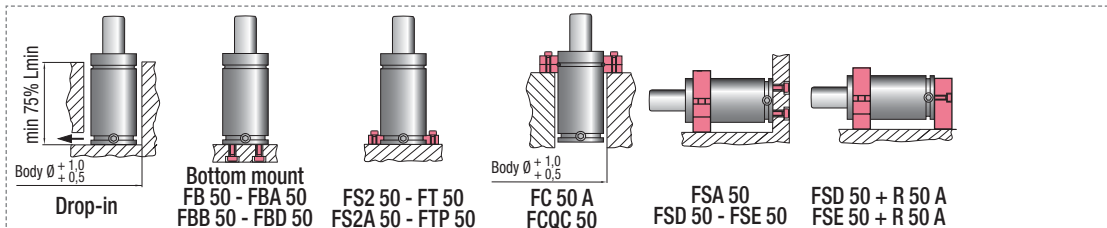

HOW TO ORDER

(10 pcs) RV 1000-050-A
 (10 pcs) RV 1000-050-A-N