

ISO 11901 - 3 B8 3180 220 000 004(MB)	VDI 3003 - Blatt 3 39D 997 (VW)	B2 4005 (BMW)	075.90.60 (FCA)
--	------------------------------------	---------------	-----------------



ACTIVE SAFETY

Il nuovo codice sarà fornito solo ad esaurimento del vecchio

The new code will be supplied only when the old will be out of stock

Der neue Kode wird geliefert nur wenn der alte nicht mehr im Lager ist

Le nouveau code sera fourni uniquement lorsque le vieux stock sera écoulé

El nuevo código será suministrado sólo cuando el viejo está fuera de stock

O novo código irá ser fornecido apenas quando o antigo esgotar stock

* $F_{1i} =$ Isothermal end force at 100% Cu p. 16 Polytrophic end force at 100% Cu



OPAS

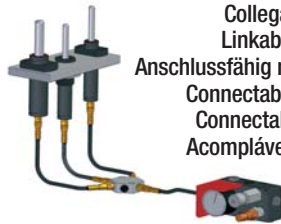

Collegabile con tubi
Linkable with hoses
Anschlussfähig mit Leitungen
Connectable avec tubes
Connectable con tubos
Acompláveis com tubos

Micro 32°

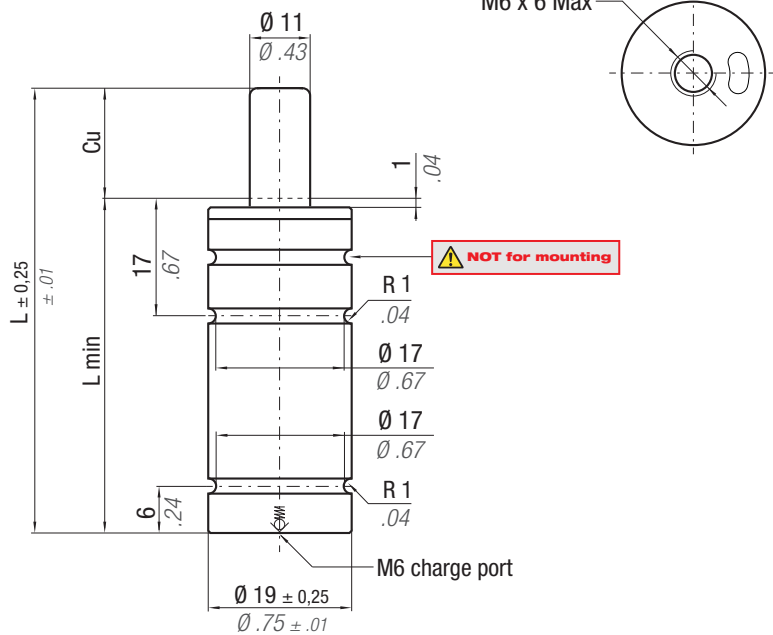

N ₂	°F 32 - 176	°C 0 - 80	ΔP ± 0,33 %/°C	P max 180 bar 2610 psi	P min 20 bar 290 psi	S 0,95 cm ² 0,147 in ²	SPM ~ 40 - 100 (at 20°C)	Max Speed 1,8 m/s	Maintenance kit Disposable
----------------	----------------------	--------------------	---------------------------	------------------------------	----------------------------	--	--------------------------------	----------------------	-------------------------------

CODE PHASING OUT from 09/2013	NEW	Cu		L		L min		F ₀ Initial force		F _{1i} * End force *		F _{1p} ** End force **		V ₀		~Kg	~lb	PED 2014/68/EU
		mm	inch	mm	inch	mm	inch	daN	lb	daN	lb	daN	lb	cm ³	in ³			
RV 170 - 007 - A	RV 170 - 007 - B	7	0.28	44	1.73	37	1.46	170 382 ± 5%	180 bar 2610 psi	256	576	295	663	2,0	0.12	0,06	0.13	✓
RV 170 - 010 - A	RV 170 - 010 - B	10	0.39	50	1.97	40	1.57			270	607	315	707	3,0	0.18	0,06	0.13	✓
RV 170 - 013 - A	RV 170 - 013 - B	13	0.51	56	2.20	43	1.69			279	628	328	738	4,0	0.24	0,07	0.15	✓
RV 170 - 015 - A	RV 170 - 015 - B	15	0.59	60	2.36	45	1.77			284	638	335	753	4,0	0.24	0,07	0.15	✓
RV 170 - 019 - A	RV 170 - 019 - B	19	0.75	68	2.68	49	1.93			291	654	346	777	5,0	0.31	0,07	0.16	✓
RV 170 - 025 - A	RV 170 - 025 - B	25	0.98	80	3.15	55	2.17			298	670	356	801	7,0	0.43	0,08	0.17	✓
RV 170 - 032 - A	RV 170 - 032 - B	32	1.26	94	3.7	62	2.44			304	683	365	820	8,0	0.49	0,09	0.19	✓
RV 170 - 038 - A	RV 170 - 038 - B	38	1.5	106	4.17	68	2.68			307	690	370	831	10,0	0.61	0,09	0.20	✓
RV 170 - 050 - A	RV 170 - 050 - B	50	1.97	130	5.12	80	3.15			312	700	376	846	13,0	0.79	0,11	0.23	✓
RV 170 - 063 - A	RV 170 - 063 - B	63	2.48	156	6.14	93	3.66			315	707	381	857	16,0	0.98	0,12	0.26	✓
RV 170 - 075 - A	RV 170 - 075 - B	75	2.95	185	7.28	110	4.33			304	684	366	822	19,0	1.16	0,14	0.30	✓
RV 170 - 080 - A	RV 170 - 080 - B	80	3.15	195	7.68	115	4.53			306	687	368	826	21,0	1.28	0,14	0.31	✓
RV 170 - 100 - A	RV 170 - 100 - B	100	3.94	235	9.25	135	5.31			310	696	373	840	25,0	1.55	0,16	0.36	✓
RV 170 - 125 - A	RV 170 - 125 - B	125	4.92	285	11.22	160	6.3			313	703	379	851	31,0	1.91	0,19	0.42	✓

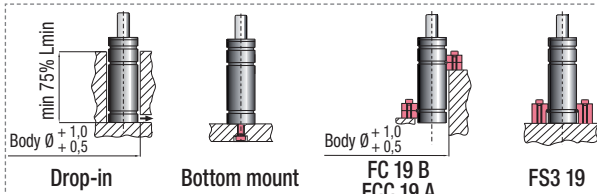

HOW TO ORDER

(10 pcs) RV 170-050-B