

ISO 11901 - 3	VDI 3003 - Blatt 3	B2 4005 (BMW)	075.90.60 (FCA)
W-DX35-6204 (Ford)	PG 24D (Mazda)	B8 3180 220 000 004(MB)	E24.54.815.G (PSA)
39D 997 (VW)			

RV 4200

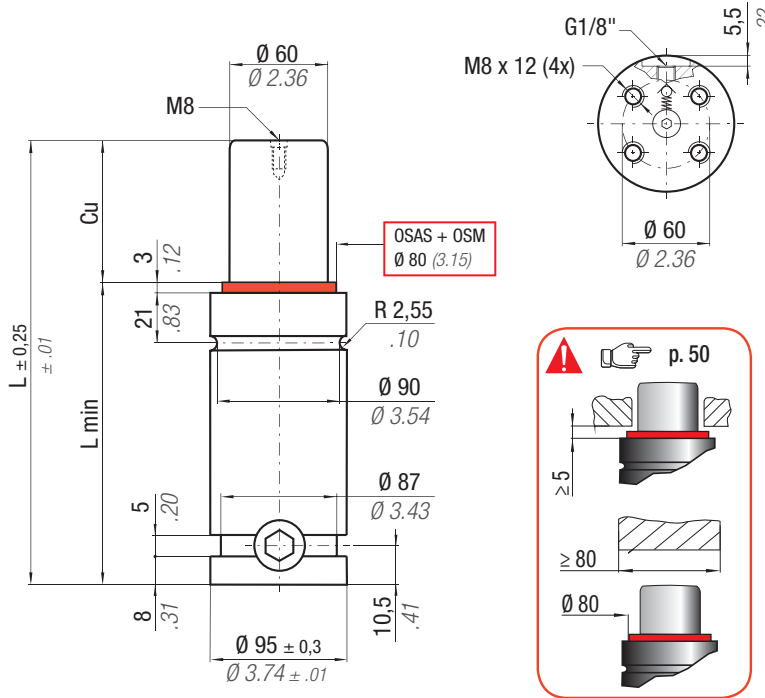

OSAS + OSM = OVER STROKE ACTIVE SAFETY + OVER STROKE MARKER



easyl MANIFOLD p. 211

ACTIVE SAFETY

* F_{1i} = Isothermal end force at 100% Cu p. 16
 ** F_{1p} = Polyphoric end force at 100% Cu



OSAS



USAS



OPAS

RV

	°F 32 - 176	°C 0 - 80	ΔP ± 0,33 %/°C	P max 150 bar 2175 psi	P min 20 bar 290 psi	S 28,27 cm ² 4.382 in ²	SPM ~ 20 - 100 (at 20°C)	Max Speed 1,8 m/s	Maintenance kit 39BMRV04200C
--	----------------------	--------------------	---------------------------	-------------------------------------	-----------------------------------	--	---------------------------------------	-----------------------------	--

CODE	Cu		L		L min		F ₀ Initial force		F _{1i} * End force		F _{1p} ** End force		V ₀		PED 2014/68/EU		
	mm	inch	mm	inch	mm	inch	daN	lb	daN	lb	daN	lb	cm ³	in ³	~Kg	~lb	
RV 4200 - 016 - A	16	0.63	90	3.54	74	2.91	4240 ± 5% 150 bar 2175 psi + 20 °C +68 °F	9532	6080	13669	7162	16101	173,0	10.55	2,76	6.08	✓
RV 4200 - 019 - A	19	0.75	96	3.78	77	3.03			6246	14041	7421	16683	193,0	11.77	2,84	6.26	✓
RV 4200 - 025 - A	25	0.98	108	4.25	83	3.27			6506	14626	7834	17612	234,0	14.27	2,99	6.59	✓
RV 4200 - 032 - A	32	1.26	122	4.80	90	3.54			6729	15128	8194	18421	281,0	17.14	3,16	6.97	✓
RV 4200 - 038 - A	38	1.50	134	5.28	96	3.78			6876	15458	8432	18956	322,0	19.64	3,31	7.30	✓
RV 4200 - 050 - A	50	1.97	158	6.22	108	4.25			7091	15940	8783	19745	403,0	24.58	3,61	7.96	✓
RV 4200 - 063 - A	63	2.48	184	7.24	121	4.76			7251	16301	9048	20341	491,0	29.95	3,94	8.69	✓
RV 4200 - 075 - A	75	2.95	208	8.19	133	5.24			7359	16543	9227	20743	572,0	34.89	4,24	9.35	✓
RV 4200 - 080 - A	80	3.15	218	8.58	138	5.43			7396	16626	9288	20880	606,0	36.97	4,36	9.61	✓
RV 4200 - 100 - A	100	3.94	258	10.16	158	6.22			7512	16888	9483	21319	741,0	45.20	4,86	10.71	✓
RV 4200 - 125 - A	125	4.92	308	12.13	183	7.20	7612	17113	9651	21696	910,0	55.51	5,48	12.08	✓		

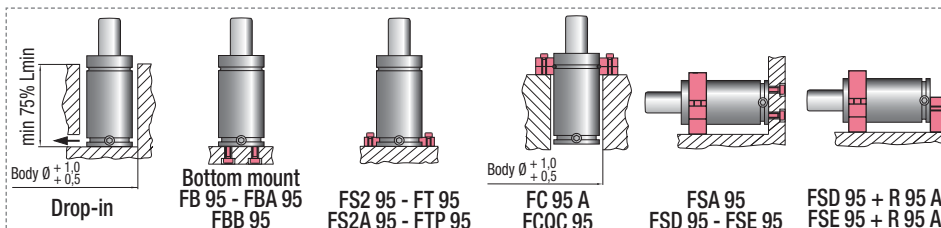

HOW TO ORDER

(10 pcs) RV 4200-050-A
 (10 pcs) RV 4200-050-A-N