

ISO 11901 - 1	VDI 3003	B2 4006 (BMW)	075.90.55 (FCA)
PG23D (Mazda)	B8 3180 220 000 001(MB)	K 32 S (Nissan)	E24.54.815.G (PSA)
EM24.54.700 (Renault)	SES-K 5404e (Suzuki)	39D 878 (VW)	

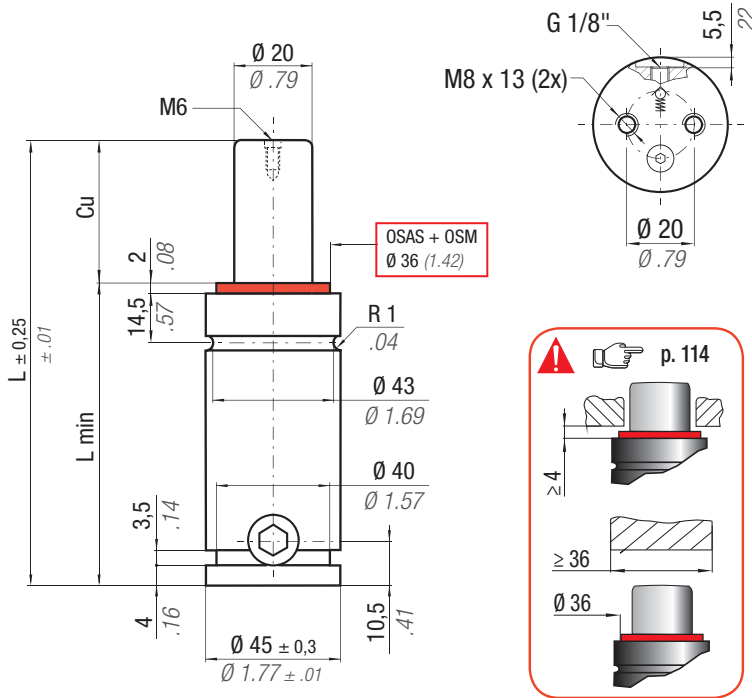

OSAS + OSM = OVER STROKE ACTIVE SAFETY + OVER STROKE MARKER

Il nuovo codice sarà fornito solo ad esaurimento del vecchio
 The new code will be supplied only when the old will be out of stock
 Der neue Kode wird geliefert nur wenn der alte nicht mehr im Lager ist
 Le nouveau code sera fourni uniquement lorsque le vieux stock sera écoulé
 El nuevo código será suministrado sólo cuando el viejo está fuera de stock
 O novo código irá ser fornecido apenas quando o antigo esgotar stock

easu MANIFOLD p. 211

* F_{1i} = Isothermal end force at 100% Cu p. 16
 ** F_{1p} = Polythropic end force at 100% Cu



ACTIVE SAFETY



OSAS



USAS



OPAS

	$^{\circ}\text{F}$ 32 - 176	$^{\circ}\text{C}$ 0 - 80	ΔP $\pm 0,33\%/^{\circ}\text{C}$	P max 150 bar 2175 psi	P min 20 bar 290 psi	S 3,14 cm ² 0.487 in ²	SPM ~ 40 - 80 (at 20°C)	Max Speed 1,8 m/s	Maintenance kit 39BMS00500D
--	--------------------------------------	------------------------------------	---	-------------------------------------	-----------------------------------	---	--------------------------------------	-----------------------------	---------------------------------------

CODE PHASING OUT from 01/2014	NEW	Cu		L		L min		F0 Initial force		F _{1i} * End force *		F _{1p} ** End force **		V0		PED 2014/68/EU		
		mm	inch	mm	inch	mm	inch	daN	lb	daN	lb	daN	lb	cm ³	in ³	~Kg	~lb	✓
-	SC 500 - 010 - D	10	0.39	105	4.13	95	3.74			595	1338	673	1512	18,0	1.10	0,90	1.98	✓
SC 500 - 013 - B	SC 500 - 013 - D	12,7	0.50	110,4	4.35	97,7	3.85			611	1373	696	1565	20,0	1.22	1,00	2.20	✓
SC 500 - 025 - B	SC 500 - 025 - D	25	0.98	135	5.31	110	4.33			652	1466	759	1707	33,0	2.01	1,09	2.40	✓
SC 500 - 038 - B	SC 500 - 038 - D	38	1.50	161	6.34	123	4.84	470	1057	673	1513	792	1780	46,0	2.81	1,20	2.65	✓
SC 500 - 050 - B	SC 500 - 050 - D	50	1.97	185	7.28	135	5.31	$\pm 5\%$		685	1539	810	1820	58,0	3.54	1,29	2.84	✓
SC 500 - 063 - B	SC 500 - 063 - D	63,5	2.50	212	8.35	148,5	5.85	150 bar		693	1558	823	1850	72,0	4.39	1,38	3.04	✓
SC 500 - 080 - B	SC 500 - 080 - D	80	3.15	245	9.65	165	6.50	2175 psi		700	1573	834	1875	89,0	5.43	1,50	3.31	✓
SC 500 - 100 - B	SC 500 - 100 - D	100	3.94	285	11.22	185	7.28	+ 20 °C + 68 °F		706	1586	843	1895	109,0	6.65	1,64	3.62	✓
SC 500 - 125 - B	SC 500 - 125 - D	125	4.92	335	13.19	210	8.27			710	1597	850	1912	135,0	8.24	1,85	4.08	✓
SC 500 - 160 - B	SC 500 - 160 - D	160	6.30	405	15.94	245	9.65			715	1606	857	1927	170,0	10.37	2,10	4.63	✓
-	SC 500 - 200 - D	200	7.87	485	19.09	285	11.22			728	1637	878	1974	205,0	12.51	2,36	5.20	✓

SC SCF

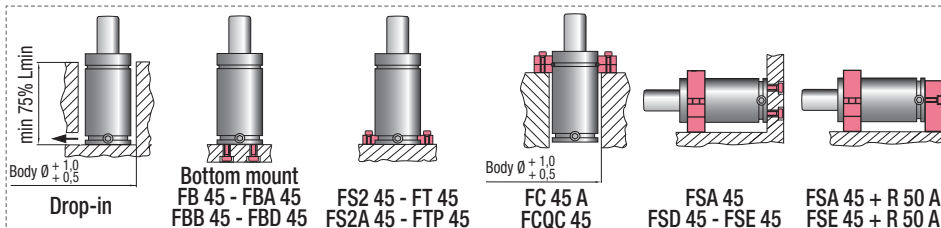

HOW TO ORDER

(10 pcs) SC 500-050-D
 (10 pcs) SC 500-050-D-N