

STANDARD KEYING LOCATIONS

STANDARD SHAPES — PUNCH VIEW

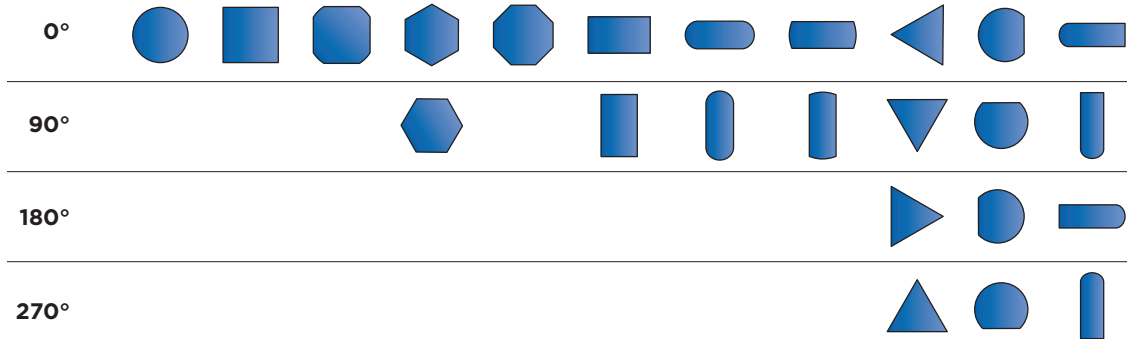

EXAMPLES OF LONG "D" AT 0°

WP0

The keys are always at 0°

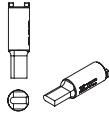
WP5

The keys are always at 90°

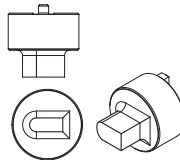
WS8 / WS9

Align shape to flats.

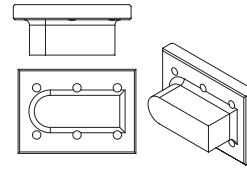
WP9

The slot is always at 0°

WSA

The single threaded holes on the top and bottom are at 90° and 270°. Align shape to flats.

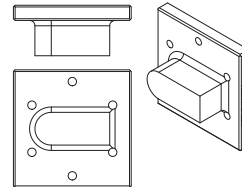
WS4

The keys (flats) are always at 0°, 90°, 180° and 270°. Align shape to flats.

WS6

Align shape to flats.

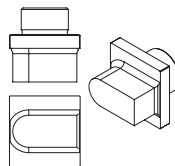

WILSON TOOL KEYING DIAGRAM

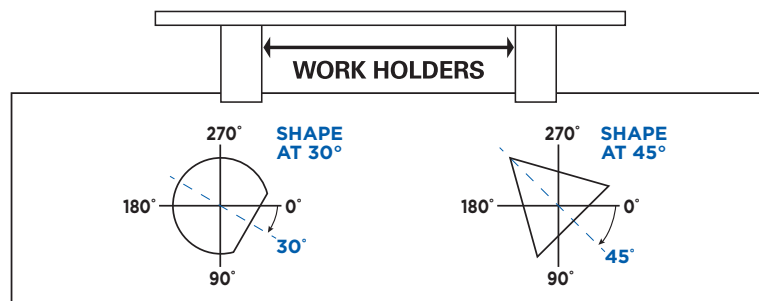

Front of Press — Punch View